



# Plena All-in-One System

PLN-6AIO240



**BOSCH**

en Installation and Operating Manual



## Table of contents

<b>1</b>	<b>Safety</b>	<b>5</b>
<b>2</b>	<b>About this manual</b>	<b>6</b>
2.1	Manual purpose	6
2.2	Digital document	6
2.3	Intended audience	6
2.4	Alerts and notice signs	6
2.5	Conversion tables	7
2.6	Copyright and disclaimer	7
2.7	Document history	7
<b>3</b>	<b>System Overview</b>	<b>8</b>
3.1	Plena	8
3.2	Plena All-in-One System	9
<b>4</b>	<b>Packaging and transportation</b>	<b>11</b>
4.1	Unpacking	11
4.2	Delivered with products	11
<b>5</b>	<b>Installation</b>	<b>12</b>
5.1	Install All-in-One Unit in 19" rack (optional)	12
5.2	Install Call Station	12
5.3	Install Wall Panel	13
<b>6</b>	<b>Connection</b>	<b>14</b>
6.1	All-in-One Unit connections	14
6.2	Microphone Adaptor connections	17
6.3	Call Station connections	18
6.4	Wall Panel connections	20
<b>7</b>	<b>Configuration</b>	<b>21</b>
7.1	All-in-One Unit configuration	21
7.1.1	Priority switches	23
7.1.2	Chime switches	23
7.2	Call Station hardware configuration	24
7.3	Call Station software configuration	25
7.3.1	Call station ID	25
7.3.2	Microphone sensitivity	26
7.3.3	Speech filter	26
7.3.4	Priority mode	26
7.3.5	Chime selection	27
7.3.6	Zone group creation	27
7.4	Wall Panel configuration	28
<b>8</b>	<b>Operation</b>	<b>29</b>
8.1	All-in-One Unit operation	29
8.2	Internal music unit	32
8.2.1	USB/SD/TUNER display	33
8.2.2	USB connector	33
8.2.3	IR remote control sensor	33
8.2.4	SD card slot	34
8.2.5	Music player	34
8.2.6	Remote control button functions	37
8.3	Call Station operation	38

---

8.4	Wall Panel operation	40
<b>9</b>	<b>Troubleshooting</b>	<b>42</b>
9.1	Customer service	43
<b>10</b>	<b>Maintenance</b>	<b>44</b>
<b>11</b>	<b>Technical Data</b>	<b>45</b>
11.1	All-in-One unit	45
11.2	Call Station	49
11.3	Wall Panel	50
11.4	Safety compliance	50

# 1 Safety

Prior to installing or operating products, always read the Important Safety Instructions which are available as a separate multilingual document: Important Safety Instructions (Safety\_ML). These instructions are supplied together with all equipment that can be connected to the mains supply.

## Safety precautions

The Plena All-in-One System is designed to be connected to the public distribution network.

- To avoid any risk of electric shock, all interventions must be carried out with disconnected mains supply.
- The ventilation should not be impeded by covering the ventilation openings.
- Connection of external wiring to this equipment requires installation by qualified personnel only.
- The operation must only be performed by qualified personnel.
- Use the apparatus in a moderate climate.



## Caution!

These service instructions are for use by qualified service personnel only.

To reduce the risk of electric shock, do not perform any servicing other than that contained in the operating instructions unless you are qualified to do so.

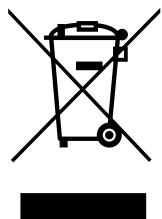

## Old electrical and electronic appliances

Electrical or electronic devices that are no longer serviceable must be collected separately and sent for environmentally compatible recycling (in accordance with the European Waste Electrical and Electronic Equipment Directive).

To dispose of old electrical or electronic devices, you should use the return and collection systems put in place in the country concerned.

## 2 About this manual

### 2.1 Manual purpose

The purpose of this manual is to provide information required for installing, configuring, operating and maintaining the Plena All-In-One System.

### 2.2 Digital document

This manual is available as a digital document in the Adobe Portable Document Format (PDF). Refer to the product related information at: [www.boschsecurity.com](http://www.boschsecurity.com).

### 2.3 Intended audience

This manual is intended for installers, operators and users of a Plena system.

### 2.4 Alerts and notice signs

Four types of signs can be used in this manual. The type is closely related to the effect that may be caused if it is not observed. These signs - from least severe effect to most severe effect - are:

**Notice!**

Containing additional information. Usually, not observing a 'notice' does not result in damage to the equipment or personal injuries.

---

**Caution!**

The equipment or the property can be damaged, or persons can be lightly injured if the alert is not observed.

---

**Warning!**

The equipment or the property can be seriously damaged, or persons can be severely injured if the alert is not observed.

---

**Danger!**

Not observing the alert can lead to severe injuries or death.

---

## 2.5 Conversion tables

In this manual, SI units are used to express lengths, masses, temperatures etc. These can be converted to non-metric units using the information provided below.

1 in =	25.4 mm	1 mm =	0.03937 in
1 in =	2.54 cm	1 cm =	0.3937 in
1 ft =	0.3048 m	1 m =	3.281 ft
1 mi =	1.609 km	1 km =	0.622 mi

**Table 2.1: Conversion of units of length**

1 lb =	0.4536 kg	1 kg =	2.2046 lb
--------	-----------	--------	-----------

**Table 2.2: Conversion of units of mass**

1 psi =	68.95 hPa	1 hPa =	0.0145 psi
---------	-----------	---------	------------

**Table 2.3: Conversion of units of pressure**



### Notice!

1 hPa = 1 mbar

$$^{\circ}\text{F} = \frac{9}{5} \cdot ^{\circ}\text{C} + 32$$

$$^{\circ}\text{C} = \frac{5}{9} \cdot (^{\circ}\text{F} - 32)$$

## 2.6 Copyright and disclaimer

All rights reserved. No part of this document may be reproduced or transmitted in any form by any means, electronic, mechanical, photocopying, recording, or otherwise, without the prior written permission of the publisher. For information on getting permission for reprints and excerpts, contact Bosch Security Systems B.V..

The content and illustrations are subject to change without prior notice.

## 2.7 Document history

Release date	Documentation version	Reason
2014.08.14	V1.0	First edition.
2014.08.18	V1.1	Section 1: WEEE added.
2014.09.03	V1.2	Sections 5.3, 11.3, and 11.4 modified.

## 3 System Overview

### 3.1 Plena

The Plena All-in-One System is part of the Plena product range. The Plena product range provides public address solutions for places where people gather to work, worship, trade, or to relax. It is a family of system elements that are combined to create public address systems tailored for virtually any application. The Plena product range includes:

- Mixers
- Pre-amplifiers
- Power amplifiers
- Music source unit
- Digital message manager
- Feedback suppressor
- Call stations
- "All-In-One" system
- Voice Alarm System
- Timer
- Charger
- Loop amplifier

The various elements are designed to complement each other using matched acoustical, electrical and mechanical specifications.



### 3.2 Plena All-in-One System

The Plena All-in-One System is an all-in-one solution for making announcements, paging people and playing background music (BGM). The system consists of the following products, which can be ordered separately:

- **PLN-6AIO240 All-in-One Unit**

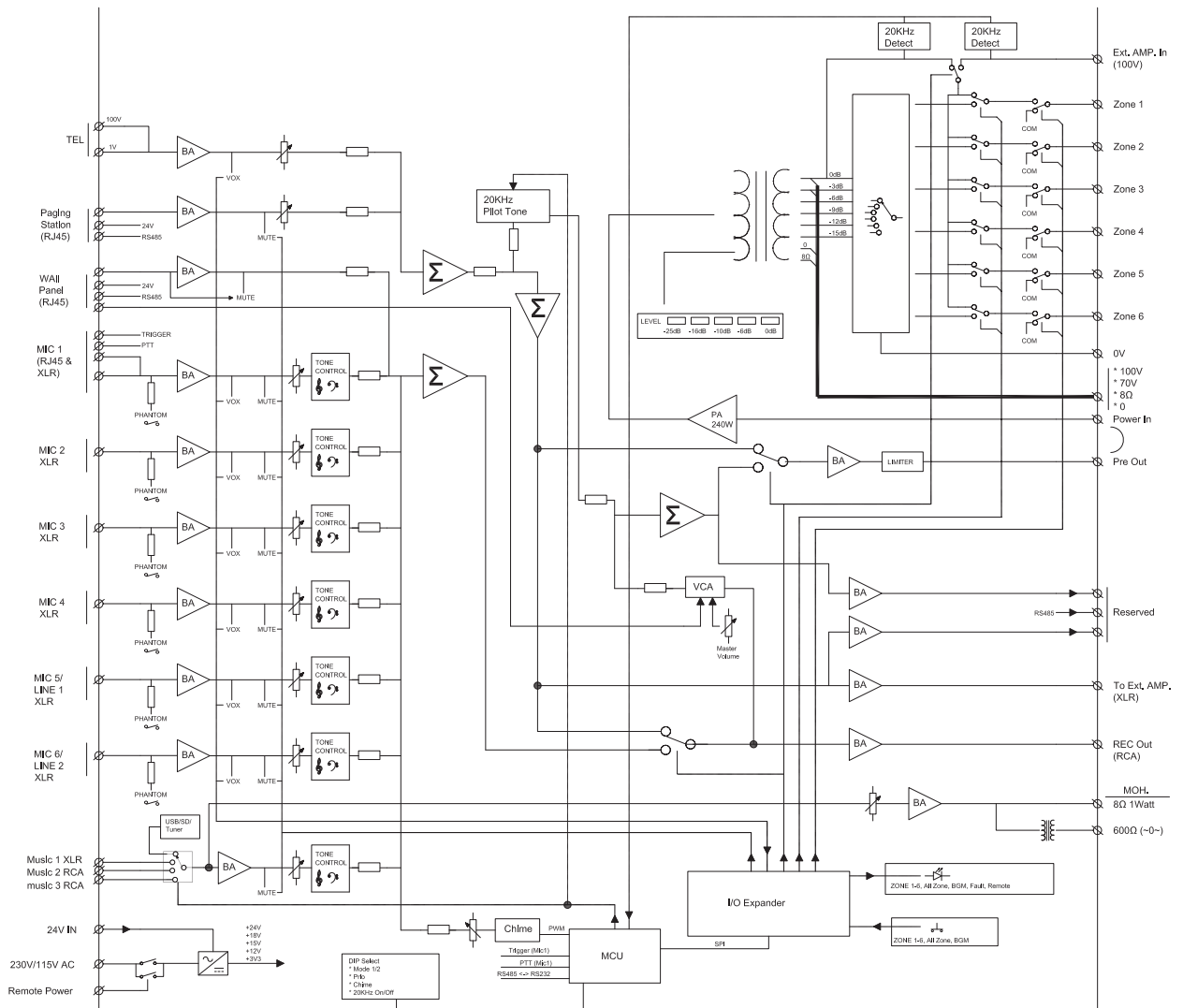

Figure 3.1: All-in-One Unit block diagram

The All-in-One Unit is the main product of the All-in-One System and integrates the following components:

- a 240 W mono mixer amplifier.
- SD and USB player that can play MP3 encoded files from SD and USB devices.
- a digitally controlled AM/FM-tuner for receiving radio stations.

Up to six microphones and three auxiliary source signals can be connected to the mixer amplifier and mixed, with priority or VOX switching. The output signal can be routed to six different zones with individual attenuation control. The unit can be extended with an additional power amplifier, e.g. LBB1935/20, as a spare amplifier or for 2-channel operation.

– **PLN-6CS Call Station**



The PLN-6CS Call Station is a remote device for making announcements to selected zones of the All-in-One System. A maximum of six Call Stations can be connected in a daisy chain configuration to the All-in-One Unit using Cat-5 cables terminated with RJ45 connectors.

– **PLN-4S6Z Wall Panel**



The PLN-4S6Z Wall Panel is used to remotely control the All-in-One Unit. It is connected to the All-in-One Unit using a Cat-5 cable terminated with RJ45 connectors.

– **PLE-1CS or PLE-1SCS Call Station**



The PLE-1CS or PLE-1SCS Call Station is an all-call call station that can be used with the All-in-One Unit for making announcements without zone selection. It is connected to the All-in-One Unit using a shielded Cat-5 cable terminated with RJ45 connectors.

## 4 Packaging and transportation

Before using the Plena All-in-One System, read this section to make sure you have all components for connecting and operating the system.

### 4.1 Unpacking

- This equipment should be unpacked and handled with care.
- If an item appears to be damaged, notify the shipper immediately.
- Carefully peel off the protective plastic film from the displays.



#### Caution!

Do not use sharp or pointed objects.

- If any items are missing, notify your Bosch representative.
- The original packaging is the safest container in which to transport products and can be used to return products for service if necessary.

### 4.2 Delivered with products

#### PLN-6AIO240 Plena All-in-One Unit

Quantity	Component
1	All-in-One Unit
1 m	Cat-5 cable with RJ45 termination for adaptor
1	Adaptor to connect a PLE-1CS or PLE-1SCS desktop microphone via shielded Cat-5 wiring
1	AC power cord (for European mains sockets)
1	Safety Instructions
1	AM indoor antenna
1	Coax connector for FM antenna
1	Pair of brackets for 19" rack installation
1	Remote control unit (without batteries)
1	Installation and Operating Manual

#### PLN-6CS Plena All-in-One Call Station

Quantity	Component
1	All-in-One Call Station
1 m	Cat-5 cable with RJ45 plugs
1	Terminator plug

#### PLN-4S6Z Plena All-in-One Wall Panel

Quantity	Component
1	All-in-One Wall Panel
1 m	Cat-5 cable with RJ45 plugs

## 5 Installation

### 5.1 Install All-in-One Unit in 19" rack (optional)

The unit is intended for tabletop use. However, the unit can also be mounted in a 19" rack. For 19" rack installation use:

- The 19" rack mounting brackets that are supplied with the product.
- The 6 screws and washers to replace the shorter screws that fix the cover to the chassis.
- Standard rack screws and cage nuts (not delivered with the product).

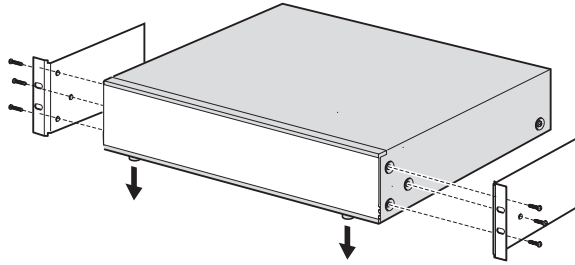

Figure 5.1: Install unit in a 19" rack

#### Notice!



If you install the unit in a 19" rack, make sure:

- the tabletop feet are removed from the bottom of the unit.
- warm air expelled from the side of the unit can flow away.
- the unit cannot exceed the maximum operating temperature (+45°C ambient).
- there is sufficient ventilation and enough room, about 10 cm / 4", behind the unit for cables and connections.

### 5.2 Install Call Station

1. The Call Station is used as a desktop device. Do not place this product where it is likely to have liquid spilt on it.
2. When installing the Call Station, do not:
  - exceed the cable manufactures' "bend radius" specifications,
  - install cabling in such a way that it becomes damaged or presents a hazard.
3. Make sure the RJ45 connectors have strong locking tabs, and cannot be inadvertently pulled out once installed. Refer to *Call Station connections*, page 18.



#### Notice!

A maximum of six call stations can be configured for each All-in-One Unit.

The maximum cable distance from the All-in-One Unit to the last Call Station is 600 m.

## 5.3 Install Wall Panel

The Wall Panel consists of a flat control panel and a rear mounting bracket, which is used for installing the product on a wall or flat surface. Cable entry is possible at the rear and sides of the mounting bracket.

This allows the mounting bracket to be used for:

- solid masonry walls, where cables run externally across the wall and enter the product from the side, or
- frame constructions, where cables are inside the cavity and need to enter the product from the rear.

1. Remove the four attachment screws on the control front panel to separate it from the mounting bracket. Do not remove other screws from the mounting bracket. They are used to secure components.
2. Gently remove the control panel from the mounting bracket and put it in a safe place. Take care not to damage the printed circuit board on the back of the control panel.
3. Attach the mounting bracket to a flat surface:
  - Make sure the RJ45 cable can easily enter the product.
  - Make sure there are no electrical cables that will be damaged by the mounting bracket attachment screws.
  - Make sure the mounting bracket is level and straight before attaching it.
  - Allow enough space around the mounting bracket so that the control panel can be easily fitted.
4. Set the jumper on the rear of the control panel:
  - Refer to *Wall Panel configuration*, page 28.
5. Feed the RJ45 cable through the mounting bracket and connect it to the RJ45 connector at the rear of the control panel.
  - To maximize the bend radius of the cable in the confined space it is strongly recommended to use the shortest RJ45 connector possible.
  - Make sure the All-in-One Unit is switched off before connecting the RJ45 cable.
  - Refer to *Wall Panel connections*, page 20.
6. Gently position the control panel in the mounting bracket, taking care not to damage the printed circuit board or the RJ45 cable.
7. Secure the control panel with the four attachment screws. Do not over-tighten.

## 6 Connection

### 6.1 All-in-One Unit connections

The following figure lists all items on the rear panel of the All-in-One Unit. This section only describes the items used for connecting the All-in-One Unit. For information on configuring the unit, refer to *All-in-One Unit configuration*, page 21.

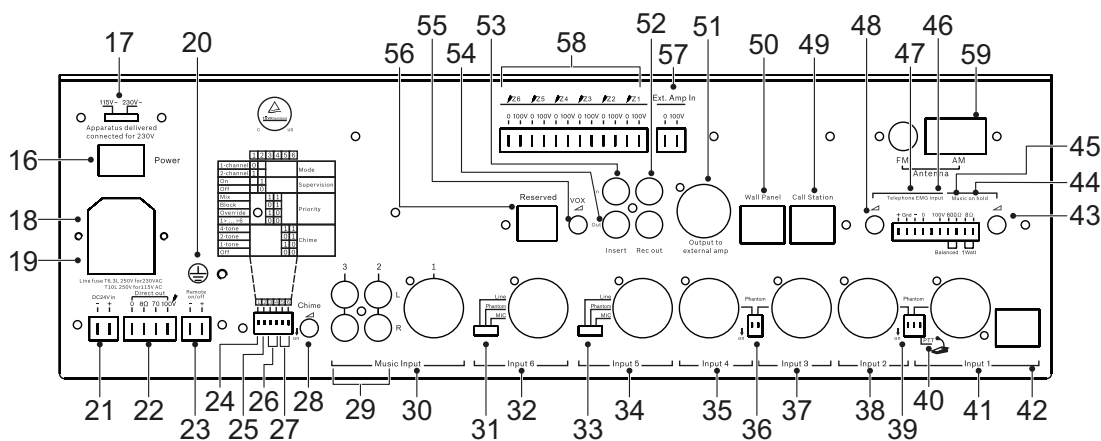

Figure 6.1: Rear panel

Number	Item	Description
18	<b>Mains power inlet</b>	Connection for mains power cord: 115/230 VAC ±15%, 50/60 Hz.
19	<b>Mains line fuse holder</b>	Only replace a fuse with one of the same type, T6.3 A for 230 V or T10 A for 115 V.
20	<b>Ground chassis</b>	Screw terminal for a ground connection to a safety ground in case the unit is not connected to a grounded electrical outlet
21	<b>DC 24 V input terminal</b>	Connection for DC 24 V power source to the input terminal. Built-in reverse polarity protection. Input voltage range: 22-28 Vdc, maximum current 12 A at -3 dB output power.
22	<b>Direct output terminals</b>	Amplifier output terminals that are not affected by the zone selectors and zone level controls. The following output terminals are available: 0 V / 8 ohm / 70 V / 100 V. The outputs are short-circuit proof.
23	<b>Remote on/off terminal</b>	If a DC 24 V (22-28 Vdc) power source is applied, the unit is powered on. To use this function correctly, the mains switch on the unit must be set to OFF and the DC 24 V backup should not be used.
29	<b>Music 2 and 3 inputs</b>	RCA sockets to connect external equipment. Stereo signals are converted into mono. <ul style="list-style-type: none"> <li>– Music input 2 sensitivity: 500 mV, 10 kohm unbalanced.</li> <li>– Music input 3 sensitivity: 300 mV, 10 kohm unbalanced.</li> </ul>
30	<b>Music input 1</b>	TRS-jack/XLR connector to connect an external mono music source. <ul style="list-style-type: none"> <li>– Input 1 sensitivity: 500 mV, 10 kohm unbalanced.</li> </ul>

Number	Item	Description
32	<b>Input 6</b>	<ul style="list-style-type: none"> <li>– Microphone or Line input 6, with TRS-jack / XLR balanced signal input connector.</li> <li>– Microphone input 6 sensitivity: 1.5 mV, 600 ohm balanced.</li> <li>– Line input 6 sensitivity: 200 mV, 10 kohm balanced.</li> </ul>
34	<b>Input 5:</b>	<ul style="list-style-type: none"> <li>– Microphone or Line input 5, with TRS-jack / XLR balanced signal input connector.</li> <li>– Microphone input 5 sensitivity: 1.5 mV, 600 ohm balanced.</li> <li>– Line input 5 sensitivity: 200 mV, 10 kohm balanced.</li> </ul>
35	<b>Input 4</b>	<ul style="list-style-type: none"> <li>– Microphone input 4, with TRS-jack / XLR balanced signal input connector.</li> <li>– Microphone input 4 sensitivity: 1.5 mV, 600 ohm balanced.</li> </ul>
37	<b>Input 3</b>	<ul style="list-style-type: none"> <li>– Microphone input 3, with TRS-jack / XLR balanced signal input connector.</li> <li>– Microphone input 3 sensitivity: 1.5 mV, 600 ohm balanced.</li> </ul>
38	<b>Input 2</b>	<ul style="list-style-type: none"> <li>– Microphone input 2, with TRS-jack / XLR balanced signal input connector.</li> <li>– Microphone input 2 sensitivity: 1.5mV, 600 ohm balanced.</li> </ul>
41	<b>Input 1</b>	<ul style="list-style-type: none"> <li>– Microphone input 1 with TRS-jack / XLR balanced signal input connector.</li> <li>– Microphone input 1 sensitivity: 1.5 mV, 600 ohm balanced</li> </ul>
42	<b>Input 1 RJ45 connector</b>	<p>This input is intended for a PLE-1CS or PLE-1SCS all-call Call Station, which is connected with a Cat-5 cable and adapter box (supplied with the unit). This allows for different length standard Cat-5 cables to be used.</p> <p>The PIN assignments of the RJ45 are as follows:</p> <ul style="list-style-type: none"> <li>– Pin 1: Audio+</li> <li>– Pin 2: Audio-</li> <li>– Pin 3: Ground</li> <li>– Pin 4: Trigger+</li> <li>– Pin 5: Trigger- (Ground)</li> <li>– Pins 6-8: Not connected</li> </ul> <p>A contact closure between pin 4 and 5 will activate the chime signal and give priority to input 1. It will mute signals on other inputs, except for the Telephone/Emergency input (<b>46/47</b>). The PTT switch (<b>40</b>) must be ON.</p>
44	<b>8Ω MOH output</b>	1 W, unbalanced Music-on-Hold output terminal for monitoring of the internal music source or Music inputs 1-3 signals, selected by the music source selector ( <b>7</b> ).
45	<b>Balanced MOH output</b>	600 ohm, 1 Vrms, transformer isolated balanced Music-on-Hold signal for monitoring of the internal music source or Music inputs 1-3 signals, selected by the music source selector ( <b>7</b> ).
46	<b>Telephone/Emergency 100 V input</b>	A balanced 100 V input, compatible with loudspeaker line signals. This input has a gate function (VOX); when the signal level exceeds a -10 dB level, it gets the highest priority and overrides all other inputs.

Number	Item	Description
47	<b>Telephone/Emergency input</b>	The same as input (46), but with an input sensitivity of 100 mV, impedance 600 ohm.
49	<b>Call station connector</b>	RJ45 connector for up to six PLN-6CS call stations connected in cascade. Ordinary shielded or unshielded Cat-5 cables can be used for interconnection. Maximum length to the last call station is 600 m. Pin assignment of this connector: <ul style="list-style-type: none"> <li>– Pin 1: Audio IN+</li> <li>– Pin 2: Audio IN-</li> <li>– Pin 3: Ground</li> <li>– Pin 4: Not connected</li> <li>– Pin 5: Not connected</li> <li>– Pin 6: + 24 Vdc &lt; 800 mA</li> <li>– Pin 7: RS485+</li> <li>– Pin 8: RS485-</li> </ul>
50	<b>Wall Panel connector</b>	RJ45 connector for one PLN-4S6Z Wall Panel. Ordinary shielded or unshielded Cat-5 cables can be used for interconnection. Pin assignment of this connector: <ul style="list-style-type: none"> <li>– Pin 1: Audio IN+</li> <li>– Pin 2: Audio IN-</li> <li>– Pin 3: Ground</li> <li>– Pin 4: Not connected</li> <li>– Pin 5: Not connected</li> <li>– Pin 6: + 24 VDC &lt; 800 mA</li> <li>– Pin 7: RS485+</li> <li>– Pin 8: RS485-</li> </ul>
51	<b>Output for external amplifier</b>	0 dBV, 600 ohm balanced output on XLR female connector for connection to an external amplifier. To be used as a second amplifier in case of dual-channel mode or as a spare amplifier.
52	<b>Rec out</b>	Record output on RCA socket. <ul style="list-style-type: none"> <li>– This output provides a 350 mV, unbalanced, mono output signal before the MASTER volume control.</li> </ul>
53	<b>Insert in</b>	Input of the power amplifier stage. In most cases this input is directly connected to the “Insert out” terminal (54), but you can connect an equalizer or other audio equipment between “Insert out” and “Insert in”. <ul style="list-style-type: none"> <li>– 0 dBV, 10 kohm unbalanced input RCA socket.</li> </ul>
54	<b>Insert out</b>	The output of internal pre-amplifier stage. <ul style="list-style-type: none"> <li>– 0 dBV, 600 ohm unbalanced input RCA socket.</li> </ul>
56	<b>RESERVED</b>	Not used.
57	<b>Ext Amp in 0-100V terminal</b>	The output of the optional external power amplifier is connected to this input. The external amplifier can be used as spare amplifier or as a second amplifier in dual-channel mode. <ul style="list-style-type: none"> <li>– Current rating maximum 7 A (50 Hz to 20 kHz).</li> </ul>



Number	Item	Description
58	<b>Zones 1-6 output terminals</b>	Output terminals for Zones 1 to 6. Each zone can be selected independently and has a 100 V-0 V terminal.
59	<b>AM/FM input terminals</b>	Set of inputs for a 300 ohm AM antenna and a 75 ohm FM antenna. An AM antenna and FM antenna connector are supplied with the unit.

## 6.2 Microphone Adaptor connections

Use the Microphone Adaptor in combination with a shielded Cat-5 cable to connect a PLE-1CS or PLE-1SCS Call Station to Input 1 RJ45 connector (42). An unshielded Cat-5 cable may pick up hum and is not recommended.



Figure 6.2: Microphone Adaptor

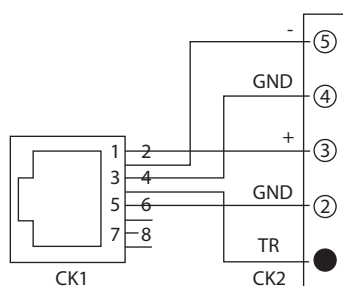

Figure 6.3: Microphone Adaptor connector layout

## 6.3 Call Station connections

The following figure lists all items of the Call Station. This section only describes the items used for connecting the Call Station. For information on configuring and operating the Call Station, refer to

- *Call Station hardware configuration, page 24*
- *Call Station software configuration, page 25*
- *Call Station operation, page 38*

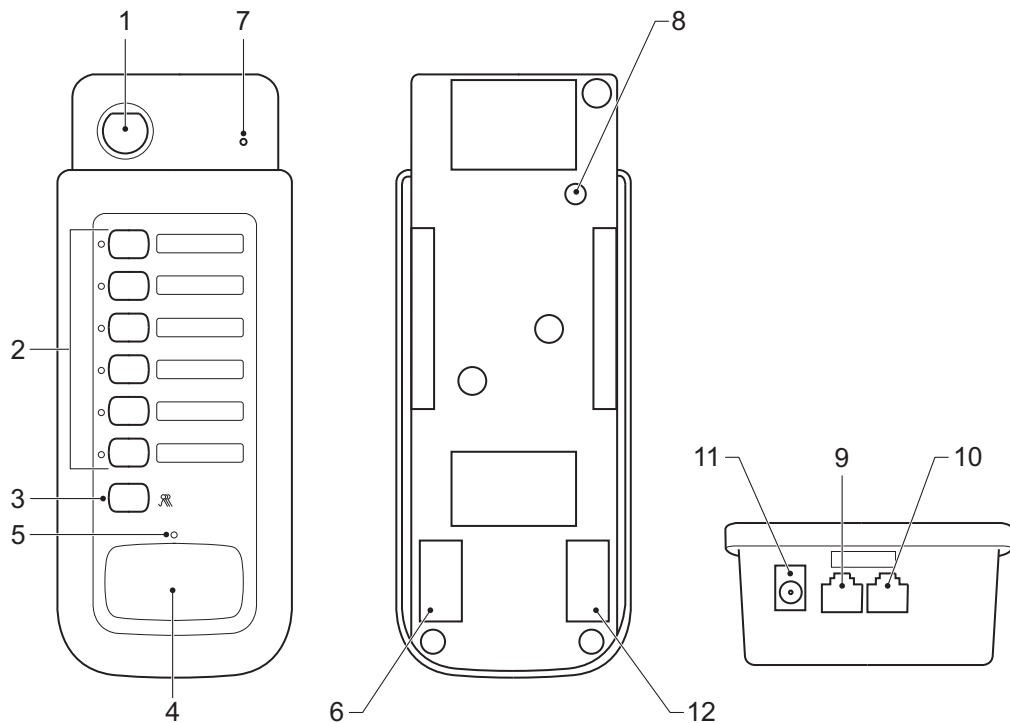

Figure 6.4: PLN-6CS Call Station connections

Number	Item	Description
6	<b>Reserved</b>	Not used.
9	<b>RJ45 connector (input)</b>	Use a standard shielded or unshielded Cat-5 cable to connect the call station to the All-in-One Unit or to the previous call station, connected in cascade.
10	<b>RJ45 connector (loop-through)</b>	Use a standard shielded or unshielded Cat-5 cable to connect the call station to the next call station, connected in cascade. The RJ45 connectors (9) and (10) are in parallel and their functions can be interchanged. The last Call Station in the chain must have a terminator plug in the free RJ45 socket for best performance with long cables. A small terminator plug that looks like an ordinary RJ45 connector is delivered with each Call Station. See <i>Delivered with products, page 11</i> . When Call Stations are cascaded some terminators are left unused, as only the last Call Station is terminated.

Number	Item	Description
11	<b>DC jack</b>	DC jack to connect an external 24 Vdc power supply +/- 10%, >100 mA. The center pin is +, the ring is -. This DC jack is only used when very long cables are used and/or multiple call stations are connected in cascade.
12	<b>Reserved</b>	Not used.

**Notice!**

A maximum of six Call Stations can be connected in cascade. The maximum cable length to the last Call Station is 600 m and the last Call Station must have a terminator plug inserted in the loop through connector.

## 6.4 Wall Panel connections

This section only describes the connection of the Wall Panel. For information on configuring and operating the Wall Panel, refer to:

- Wall Panel configuration, page 28
- Wall Panel operation, page 40

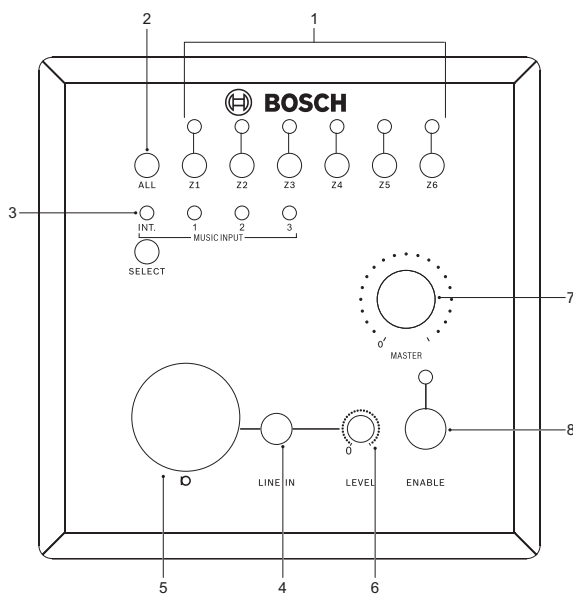

Figure 6.5: Wall Panel connections

Number	Item	Description
4	<b>Line input</b>	A line input, on a 3.5 mm (1/8") stereo phone jack socket, for a local music source, e.g. the headphone output of a smart phone. The signal is mixed with the microphone on the Wall Panel microphone input (5) and any microphone/line signal on inputs 1-6 of the All-in-One Unit. The signal priority is the same as the music inputs of the All-in-One Unit. The sensitivity is 200 mV unbalanced, stereo converted to mono, with an input impedance of 10 kohm.
5	<b>Microphone input</b>	A microphone input, on a female XLR socket, for a local microphone. The signal is mixed with the line input on the Wall Panel (4) and any microphone/line signal on inputs 1-6 of the All-in-One Unit. The signal priority is the same as the music inputs of the All-in-One Unit. The sensitivity is 2 mV balanced, with input impedance 600 ohm. There is a phantom power supply that can be configured with an internal jumper.
Not shown on drawing	<b>RJ45 socket</b>	The Wall Panel is connected to the All-in-One Unit with a Cat-5 cable terminated with RJ45 connectors. The cable is for RS485 data communication and also provides DC power for the Wall Panel. The RJ45 socket is inside the Wall Panel. To access the socket, remove the front control panel, as described in <i>Install Wall Panel</i> , page 13. <b>Note:</b> Do NOT use a RJ45 cable boot or sleeve to terminate this cable. This may result in the cable not fitting into the device or its bend radius being exceeded.

# 7 Configuration

## 7.1 All-in-One Unit configuration

The following figure lists all items on the rear panel of the All-in-One Unit. This section only describes the items used for configuring the All-in-One Unit. For information on connecting the unit, refer to *All-in-One Unit connections*, page 14.

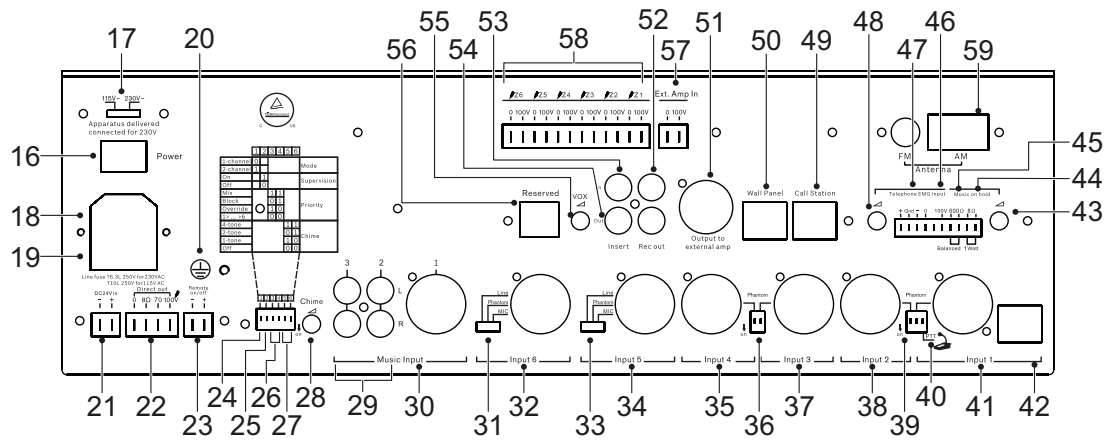

Figure 7.1: Rear panel

Number	Item	Description
17	<b>Mains line voltage selector</b>	A slider switch to select the AC line voltage (115 Vac/230 Vac) to the mains voltage of the country where the unit is being used.
24	<b>Mode selection</b>	<ul style="list-style-type: none"> <li>- <b>Single channel (Mode 1)</b> - the internal power amplifier serves as the power amplifier for both music and calls. An optional external power amplifier, connected between terminals (51) and (57), will act as a spare amplifier in case amplifier supervision is enabled with switch (25). In single channel mode, music will be interrupted when a call is made.</li> <li>- <b>Dual channel (Mode 2)</b> - the internal power amplifier serves as the power amplifier for the music channel, while the external power amplifier, connected between terminals (51) and (57), serves as the amplifier for the call channel. In case supervision is enabled with switch (25), the internal power amplifier will also serve as a spare amplifier for the call channel. In dual channel mode, zones with music will not be interrupted by calls to another zone.</li> </ul>

Number	Item	Description
25	<b>Supervision (20 kHz) switch</b>	<ul style="list-style-type: none"> <li>– When set to ON, an inaudible 20 kHz pilot tone is added to the audio signal and the power amplifier supervision is enabled. When the power amplifier fails and the pilot tone cannot be detected anymore, the Fault LED will illuminate and, if available, the spare amplifier will take over. The pilot tone detection threshold on the 100 V terminal is 10 V +3 dB/-1 dB.</li> <li>– When the Supervision switch is set to OFF, no pilot tone is present and no supervision or spare amplifier switching takes place. Power consumption and heat production is lowest when Supervision is OFF.</li> </ul>
26	<b>Priority switches</b>	Two switches are used to set the Priority. See <i>Priority switches</i> , page 23.
27	<b>Chime switches</b>	Two switches are used to set the chime tone. See <i>Chime switches</i> , page 23. Only the chime for Microphone 1, PLE-1CS or PLE-1SCS, on terminal <b>(42)</b> is changed.
28	<b>Chime level</b>	Adjusts chime output level. Only the chime level for Microphone 1, PLE-1CS or PLE-1SCS, on terminal <b>(42)</b> is changed.
31	<b>Input 6 Line/Phantom/ Microphone selector</b>	Switch to select the sensitivity and phantom power of Input 6. The Phantom mode is valid for microphone sensitivity only (Phantom: 18 V @ no load).
33	<b>Input 5 Line/Phantom/ Microphone selector</b>	Switch to select the sensitivity and phantom power of Input 5. The Phantom mode is valid for microphone sensitivity only (Phantom: 18 V @ no load).
36	<b>Phantom power ON/OFF switch for Inputs 3 and 4 independently</b>	Switch to set the phantom power to ON (Phantom: 18 V @ no load).
39	<b>Phantom power ON/OFF switch for Inputs 1 and 2 independently</b>	Switch to set the phantom power to ON (Phantom: 18 V @ no load).
40	<b>Press To Talk (PTT) switch</b>	<ul style="list-style-type: none"> <li>– PTT switch set to ON: A microphone connected to terminal <b>(41)</b> will be disabled, but an all-call Call Station PLE-1CS or PLE-1SCS, connected to terminal <b>(42)</b>, allows speech to all zones and an optional chime signal.</li> <li>– PTT switch set to OFF: Microphone input 1 is enabled. A connected PLE-1CS or PLE-1SCS is not disabled but just mixed with Microphone input 1, without a chime signal.</li> </ul>
43	<b>MOH level adjustment</b>	Adjusts the output level of the “Music On Hold” signal on outputs <b>(44)</b> and <b>(45)</b> .

Number	Item	Description
48	<b>Telephone/Emergency level adjustment</b>	Adjusts the output level for the Telephone/Emergency signal applied to inputs (46) and/or (47). This adjustment does not change the sensitivity of the input gate (VOX).
55	<b>Ducking level</b>	Attenuates the music level from the internal music source or Music inputs 1-3 when the priority mute function is activated. - The ducking attenuation is adjustable in the range 0 to -60 dB.

### 7.1.1 Priority switches

Two switches (26) to set the Priority of inputs 1 to 6. The Telephone/Emergency input has highest priority and always overrides all other inputs:

Switch setting	Priority	Remark
00	Serial: 1 > 2 > 3 > 4 > 5 > 6	<ul style="list-style-type: none"> <li>- Input 1 has highest priority.</li> <li>- Input 6 has lowest priority.</li> </ul>
01	Block	<ul style="list-style-type: none"> <li>- The first activated input gets priority.</li> <li>- Other inputs are muted (blocked).</li> </ul>
10	Override	<ul style="list-style-type: none"> <li>- The last activated input gets priority.</li> <li>- The other inputs are overridden.</li> </ul>
11	Mix	<ul style="list-style-type: none"> <li>- No priority.</li> <li>- All inputs are mixed.</li> </ul>

Table 7.1: Priority switches settings

### 7.1.2 Chime switches

Two switches (27) to select the chime on input 1 for a PLE-1CS or PLE-1SCS. The PLN-6CS call stations have their own chime selector:

Switch setting	Chime	Frequency
00	No chime	
01	1-tone chime	554 Hz
10	2-tone chime	554/440 Hz
11	4-tone chime	294/392/495/588 Hz

Table 7.2: Chime switches settings

## 7.2 Call Station hardware configuration

The following figure lists all items of the Call Station. This section only describes the hardware configuration of the Call Station. For information on connecting and operating the Call Station, refer to

- *Call Station connections, page 18*
- *Call Station operation, page 38*

The programmable features of the call station are explained in *Call Station software configuration, page 25*.

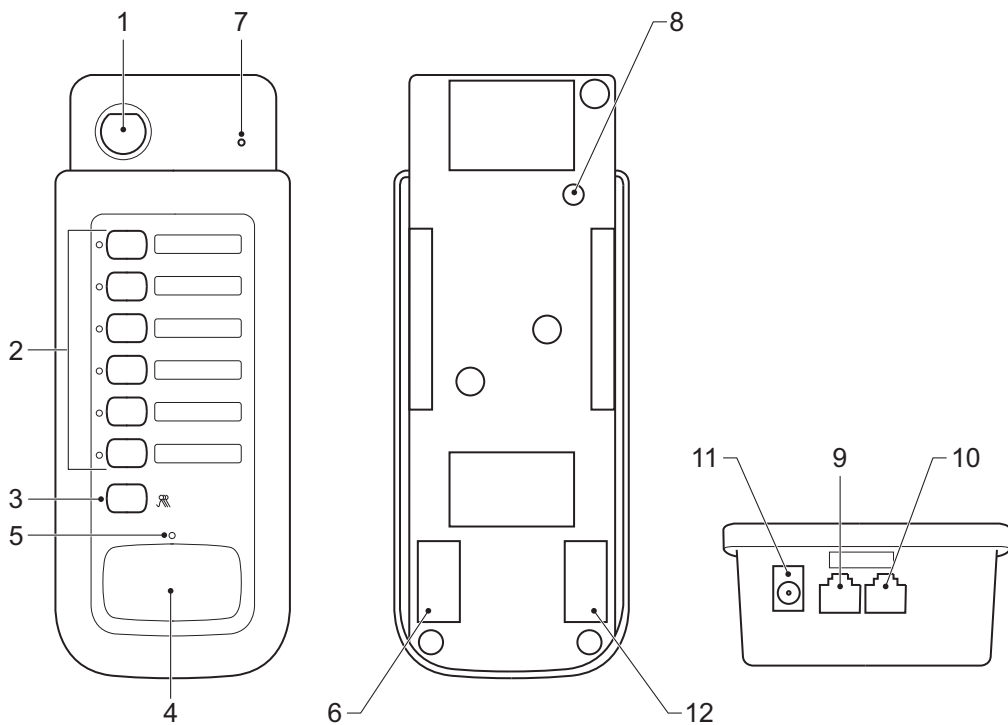

Figure 7.2: Call Station

Number	Item	Description
8	<b>Output level adjust</b>	Use a small screwdriver to adjust the call station output level. This setting determines how loud a call is in the zones and is independent of the master volume setting of the All-in-One Unit to make sure that each call comes through.



## 7.3 Call Station software configuration

### 7.3.1 Call station ID

The call station ID in each call station is used to set the priorities between the Call Stations, depending on the configured Priority mode. Only a maximum of six Call Stations can be cascaded and connected to an All-in-One Unit, so IDs 7 and 8 should not be used. All Call Stations must have a unique ID.

1. Press the **PTT** button and **Zone 6** button simultaneously for more than 3 seconds, the Talk LED and Zone 6 LED will flash to indicate this configuration mode.
2. Press button **Zone 6** repeatedly to step through eight different ID settings sequentially. The Zone 1-4 LEDs show the selected ID (0 = LED off, 1 = LED on).
3. Press the **PTT** button to store the selected ID for this call station and exit.

Call station ID	Zone 4 LED	Zone 3 LED	Zone 2 LED	Zone 1 LED
1	0	0	0	1
2	0	0	1	0
3	0	0	1	1
4	0	1	0	0
5	0	1	0	1
6	0	1	1	0
(7)	0	1	1	1
(8)	1	0	0	0

**Table 7.3: Call station ID settings**

### 7.3.2 Microphone sensitivity

The setting for the microphone sensitivity sets the gain of the microphone amplifier in front of the signal limiter. The output level preset (item **(8)** in *Call Station hardware configuration, page 24*) sets the volume of the output after the signal limiter. Note that these are two different things. The output level sets the maximum loudness of the announcements in the zones, while the sensitivity setting compensates for loud or soft speaking voices. Soft speakers or speakers that keep much distance from the microphone should use a high sensitivity. Be careful with selecting a high sensitivity in combination with a high output level, when the zone loudspeakers are in the same area as the call station. This might result in acoustic feedback (howling).

1. Press the **PTT** button and **Zone 5** button simultaneously for more than 3 seconds, the Talk LED and Zone 5 LED will flash to indicate this configuration mode.
2. Press button **Zone 5** repeatedly to step through the six different sensitivity settings sequentially. The Zone 1-3 LEDs show the selected sensitivity (0 = LED off, 1 = LED on).
3. Press the **PTT** button to store the selected sensitivity and exit.

Sensitivity	Zone 3 LED	Zone 2 LED	Zone 1 LED
1	0	0	1
2	0	1	0
3	0	1	1
4	1	0	0
5	1	0	1
6 (max)	1	1	0

**Table 7.4: Microphone sensitivity settings**

### 7.3.3 Speech filter

The speech filter removes the lowest frequencies of the speech signal, that are especially present when talking close into the microphone. Removing the lowest frequencies reduces the risk for amplifier overloading and in general improves intelligibility.

1. Press the **PTT** button and **Zone 2** button simultaneously for more than 3 seconds, the Talk LED and Zone 2 LED will flash to indicate this configuration mode.
2. Press button **Zone 2** to toggle between a flat frequency response and the filtered response. The Zone 2 LED shows the selected filter setting (0 = LED off, 1 = LED on).
3. Press the **PTT** button to store the speech filter setting and exit.

Speech filter	Zone 2 LED	Remark
Filtered response	0	Low cut @ 315 Hz (-3 dB), 6 dB/octave
Flat response	1	

**Table 7.5: Speech filter settings**

### 7.3.4 Priority mode

This setting determines what happens when more than one Call Station is connected to the All-in-One Unit. For consistent behavior make sure that all connected Call Stations use the same setting.

1. Press the **PTT** button and **Zone 4** button simultaneously for more than 3 seconds, the Talk LED and Zone 4 LED will flash to indicate this configuration mode.
2. Press button **Zone 4** repeatedly to step through the four different priority modes sequentially. The Zone 1-3 LEDs show the selected priority mode (0 = LED off, 1 = LED on).
3. Press the **PTT** button to store the selected priority mode and exit.

Priority mode	Zone 3 LED	Zone 2 LED	Zone 1 LED
Serial priority: 1>2>3>4>5>6, Call Station 1 has highest priority	0	0	1
Blocking priority: the active Call Station keeps priority	0	1	0
Override mode: the last Call station will get priority	0	1	1
Mixing mode: all Call Stations have equal priority and audio is mixed	1	0	0

**Table 7.6: Priority mode settings**

### 7.3.5

#### Chime selection

This setting selects the type of chime at the start of a call to draw the attention of the audience, in order not to miss the first words of the announcement.

1. Press the **PTT** button and **Zone 3** button simultaneously for more than 3 seconds, the Talk LED and Zone 3 LED will flash to indicate this configuration mode.
2. Press button **Zone 3** repeatedly to step through the four different chime settings sequentially. The Zone 1 and 2 LEDs show the chime setting (0 = LED off, 1 = LED on).
3. Press the **PTT** button to store the selected chime setting and exit.

Chime setting	Zone 2 LED	Zone 1 LED
No chime	0	0
1-tone chime (554 Hz)	0	1
2-tone chime (554/440 Hz)	1	0
4-tone chime (294/392/495/588 Hz)	1	1

**Table 7.7: Chime selection settings**

### 7.3.6

#### Zone group creation

This configuration creates sets of zones that are assigned to a single zone button, to speed up the selection of zones that are frequently addressed together. Note that when a zone group is assigned to a zone button, this button is not available anymore for direct selection of that zone.

1. Press the **PTT** button and **Zone 1** button simultaneously for more than 3 seconds, all Zone 1-6 LEDs will flash to indicate this configuration mode.
2. Press one button (from buttons **Zone 1-6**) to store the zone group setting. All **Zone 1-6** LEDs flash again. Then select the required zones for this zone group.
3. Press the **PTT** button to store the created zone groups and exit.

## 7.4 Wall Panel configuration

This section only describes the configuration of the Wall Panel. For information on connecting and operating the Wall Panel, refer to:

- *Wall Panel connections, page 20*
- *Wall Panel operation, page 40*

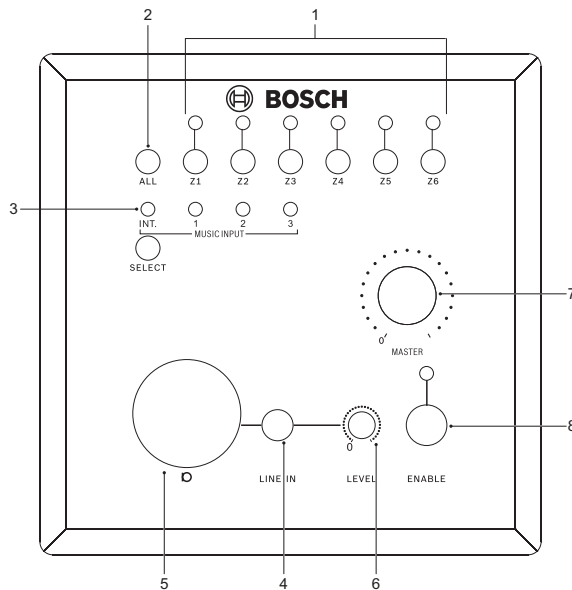

Figure 7.3: Fig 8-5

Number	Item	Description
6	<b>Level control</b>	Used to adjust the output level for the Line and Microphone inputs on the Wall Panel to the All-in-One Unit.
Not shown on drawing	<b>2-pin jumper connector</b>	The Wall Panel has an internal 2-pin jumper connector to select phantom power for the microphone connected to the XLR-connector. To access the jumper, remove the front control panel as described in <i>Install Wall Panel, page 13</i> . <ul style="list-style-type: none"> <li>- Jumper connected: phantom power ON.</li> <li>- Jumper removed: phantom power OFF.</li> </ul>

# 8 Operation

## 8.1 All-in-One Unit operation

The following figures list all items on the rear and front panels of the All-in-One System. This section only describes the items used for operating the All-in-One System. For information on connecting and configuring the system refer to:

- All-in-One Unit connections, page 14
- All-in-One Unit configuration, page 21

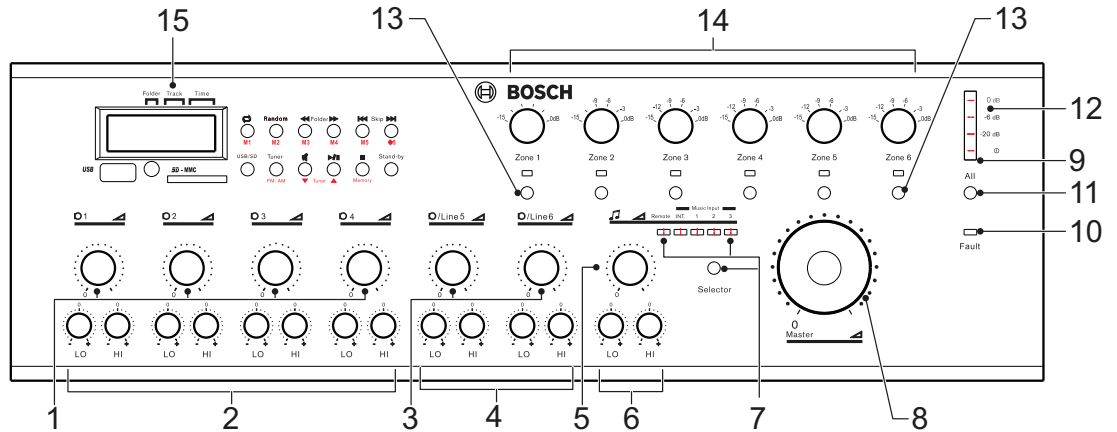

Figure 8.1: Front panel

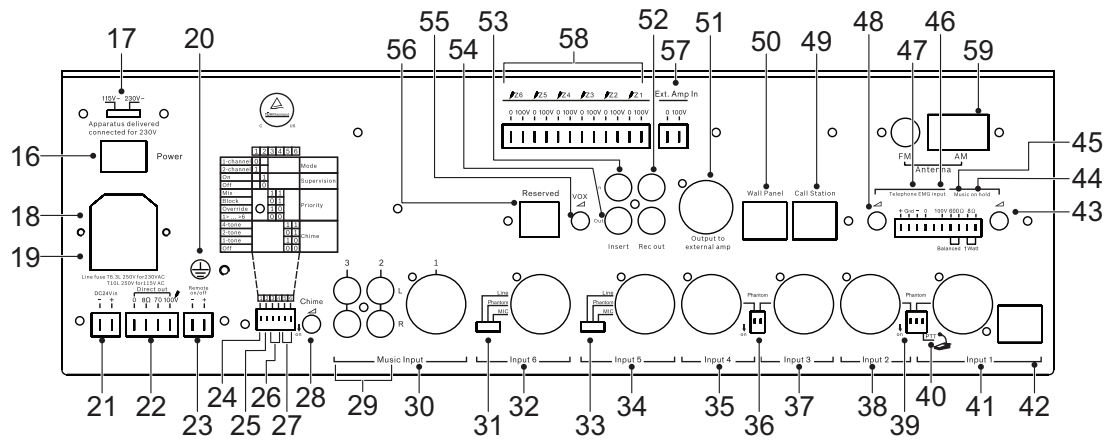

Figure 8.2: Rear panel

Number	Item	Description
1	<b>Inputs 1-4 level control</b>	A rotary control to adjust the Microphone 1-4 signal levels.
2	<b>HI/LO frequency control for inputs 1-4</b>	A recessed rotary control with a center detent to adjust the high and low frequencies of Microphone 1-4 signals. Remove the insert for access to the control. Control range: <ul style="list-style-type: none"> <li>- LO = 100 Hz ± 8 dB</li> <li>- HI = 10 kHz ± 8 dB</li> </ul>
3	<b>Inputs 5-6 level control</b>	A rotary control to adjust the Microphone/Line 5-6 signal levels.

Number	Item	Description
4	<b>HI/LO frequency control for inputs 5-6</b>	A recessed rotary control with a center detent to adjust the high and low frequencies of Microphone 5-6 signals. Remove the insert for access to the control. Control range: <ul style="list-style-type: none"> <li>– LO = 100 Hz ± 8 dB</li> <li>– HI = 10 kHz ± 8 dB</li> </ul>
5	<b>Music level control</b>	A rotary control to adjust the level of the selected music source.
6	<b>HI/LO control for music inputs 1-3</b>	A recessed rotary control with a center detent to adjust the high and low frequency of the selected music source. Remove the insert for access to the control. Control range: <ul style="list-style-type: none"> <li>– LO = 100 Hz ± 8 dB</li> <li>– HI = 10 kHz ± 8 dB</li> </ul>
7	<b>Music source selector and indicators</b>	Press the <b>Selector</b> button repeatedly to select sequentially between the internal music source (SD/USB/tuner) and one of the three music inputs on the rear panel. A green LED shows the source selected. When a PLN-4S6Z Wall Panel is connected and enabled to have control, the <b>Remote</b> LED is ON. Pressing the <b>Selector</b> button will then first disable the Wall Panel before switching to the next music input. With the <b>Selector</b> button the internal music player can be selected with and without Wall Panel control. For the other music inputs, control by the Wall Panel must be enabled from the Wall Panel itself.
8	<b>Master volume control</b>	A rotary control to adjust the overall output signal of the unit. <ul style="list-style-type: none"> <li>– The master volume control has no effect on the volume of the PLN-6CS Call Station and on the volume of the Telephone/Emergency signal. The PLN-6CS has its own volume setting that must be set for best intelligibility. The Telephone/Emergency input also has its own volume setting (<b>48</b>).</li> <li>– The volume level of all other inputs is controlled by the master volume control of either the All-in-One Unit or the Wall Panel.</li> </ul>
9	<b>Power LED</b>	The green power LED indicates power on.
10	<b>Fault LED</b>	The Fault LED lights up amber to indicate that the pilot tone detecting circuit has not found a pilot tone at the output of the internal or external amplifier. This will only occur when the unit is in supervisory mode, see item ( <b>25</b> ) in <i>All-in-One Unit configuration</i> , page 21. <b>Note:</b> The Plena All-in-One System is not certified for voice alarm purposes. When there is no special reason to supervise the built-in or external amplifier, it is recommended to switch off supervision to reduce the power consumption of the device.
11	<b>All (zones) switch and indicator</b>	When the <b>All</b> switch is pressed, all zones are switched on and all output zone LEDs light up
12	<b>LED VU meter</b>	Indicates the output signal level. Accuracy is between +0 / -3 dB, where: <ul style="list-style-type: none"> <li>– 0 dB = red</li> <li>– -6 dB = amber</li> <li>– -20 dB = amber</li> <li>– Power on = green</li> </ul>

Number	Item	Description
13	<b>Zone 1 - 6 select switches and indicators</b>	Push a switch to select an output zone. Each zone can be selected independently. When a zone is selected the corresponding green LED is on, and audio signals are routed to that zone. If a call is made from a call station with locally selected zones, or when a signal is detected on the Telephone/Emergency input, the green LEDs of all addressed zones will flash. When a call has ended, the zone status returns to its previous state.
14	<b>Zone output attenuators</b>	Rotary controls to attenuate the output level of each zone independently, using the following attenuation steps: 0dB / -3dB / -6dB / -9dB / -12dB / -15dB.
15	<b>Built-in music source</b>	The music source comprises an AM/FM tuner and a USB/SD card player. See <i>Internal music unit</i> , page 32.
16	<b>Power switch</b>	Switches the unit power on and off: <ul style="list-style-type: none"> <li>- I = unit power ON</li> <li>- 0 = unit power OFF</li> <li>- <b>Caution!</b> Risk of potential damage to unit. Before connecting power, always check the voltage selector (<b>17</b>) (on the rear panel of the unit) to ensure it is set to the correct country voltage.</li> </ul>

## 8.2 Internal music unit

The All-In-One unit contains an internal music unit that includes a USB/SD MP3 player and an FM/AM Tuner. The LCD displays the operational state of the unit. There are 12 front panel buttons for operational functions. In addition, the IR remote control can also be used to control the audio source unit.

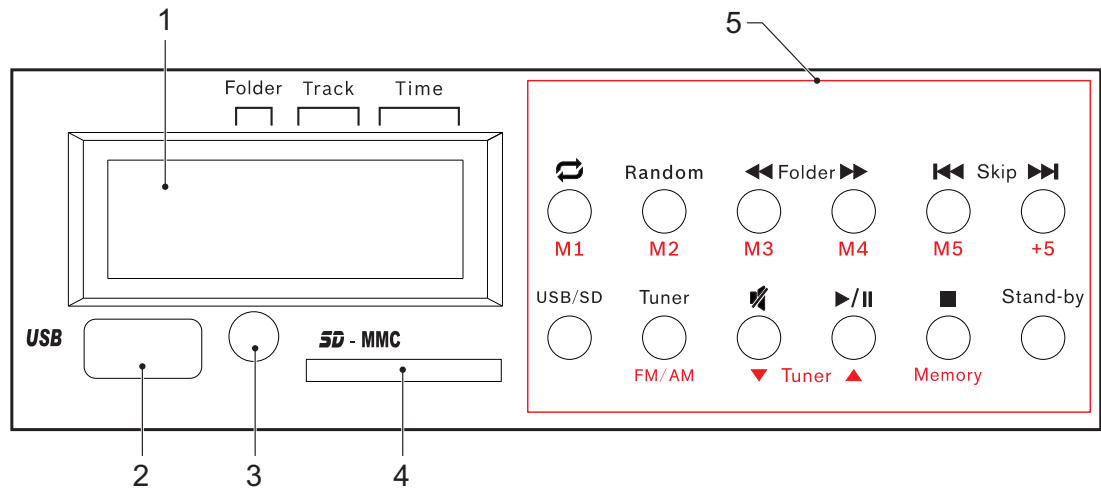

**Figure 8.3: Audio source module**

1. *USB/SD/TUNER display, page 33*
2. *USB connector, page 33*
3. *IR remote control sensor, page 33*
4. *SD card slot, page 34*
5. *Music player, page 34*

Each item is explained in the following sections.



### 8.2.1 USB/SD/TUNER display

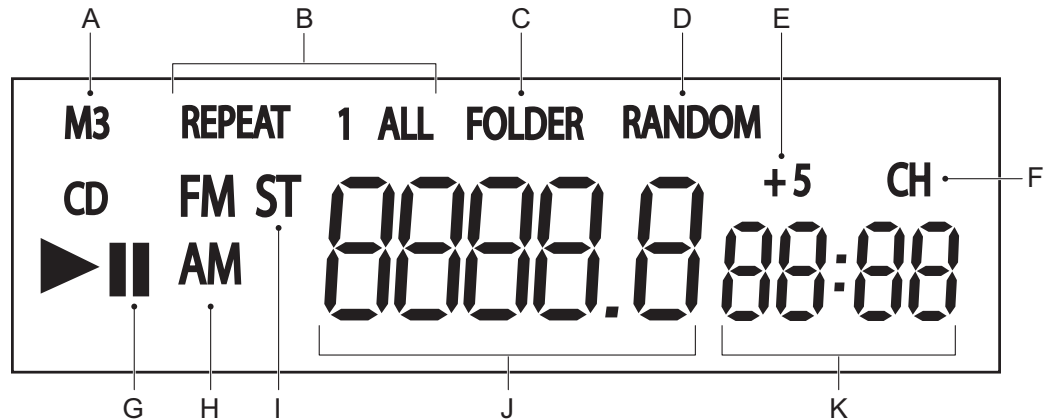

Figure 8.4: SD/USB/TUNER LCD display (1)

- (A) MP3 indicator
- (B) Repeat 1 song or Repeat All indicator
- (C) Repeat folder indicator
- (D) Randomize indicator
- (E) +5 preset indicator
- (F) CH (channel) indicator
- (G) Play or Pause status
- (H) Radio band indicator
- (I) Radio FM stereo indicator
- (J) Frequency, or song number or folder number
- (K) Duration time of song or preset status

### 8.2.2 USB connector

Only use a USB memory stick or flash drive with a maximum current consumption of 500 mA. Do not connect USB hard disks. Maximum supported memory size is 32 GB.

To use the USB connector (2):

1. Plug-in the USB flash drive to the USB connector.
2. Press **Standby** to power on the music source and/or press **USB/SD** to select the USB device.
3. While the music player is reading the content of the USB device, the LCD displays 'USB' flashing.
  - If the content reading is successful, the first track found will be played.
  - If the content reading is unsuccessful, the LCD displays 'none'.
4. When playing from the USB flash drive has finished, the player will resume playback from the tuner automatically.

### 8.2.3 IR remote control sensor

The IR sensor (3) receives an IR signal from the remote control supplied with the unit. The maximum distance in an open field is 10 m, and a direct line of sight is needed.

## 8.2.4

### SD card slot

Only use high capacity SD cards (HCSD) up to 32 GB for this unit.

To use the SD card slot (4):

1. Insert the SD card into the SD card slot.
2. Press **Standby** to power on the music source, and/or press **USB/SD** to select the SD device.
3. While the music player is reading the content of the SD card, the LCD displays 'SD' flashing:
  - If the content reading is successful, the first track found will be played.
  - If the content reading is unsuccessful, the LCD displays 'none'.
4. When playing from the SD card has finished, the player will resume playback from the tuner automatically.



#### Notice!

The USB connector and SD card slot support devices up to 32 GB in FAT32 format or up to 4 GB in FAT16 format. MP3 files can be between 32 .. 320 kbps.

## 8.2.5

### Music player

General music player button functions are explained in the table below. For the location of each button, see item **5** in Section *Internal music unit*, page 32.

Button	Function	Instructions
<b>Stand-by</b>	<b>Power the audio player on or off</b>	Press the <b>Stand-by</b> button to power on the audio player. The unit resumes playing from the last state it was in before the unit was switched off. This state will be shown on the LCD. Press the stand-by button again to switch the player off. The LCD will turn off and all other functions are cancelled.
<b>USB/SD</b>	<b>USB/SD select button</b>	Press the <b>USB/SD</b> button to select between USB or SD card.
<b>Tuner</b>	<b>Tuner select button</b>	Press the <b>Tuner</b> button to select the Tuner mode.

**Table 8.1: General audio unit button functions**

The following table explains button functions that are used when the music player is in MP3 playback mode. For the location of each button, see item **5** in Section *Internal music unit*, page 32.









Button	Function	Instructions
	<b>Repeat playback</b>	To repeat playback of one or more songs on the USB or SD device: <ul style="list-style-type: none"> <li>– Press the <b>Repeat</b> button to repeat playback of the current song. The LCD displays 'REPEAT 1'.</li> <li>– Press the <b>Repeat</b> button again to repeat playback of the current folder. The LCD displays 'REPEAT FOLDER'.</li> <li>– Press the <b>Repeat</b> button once again to repeat playback of all songs on the device. The LCD displays 'REPEAT ALL'.</li> <li>– Press the <b>Repeat</b> button again to cancel the repeating playback function.</li> </ul>
<b>Random</b>	<b>Random playback</b>	<b>Random mode:</b> <ul style="list-style-type: none"> <li>– Press the <b>Random</b> button to randomly playback all songs on the selected USB/SD device. The LCD displays 'RANDOM'.</li> <li>– Press the <b>Random</b> button once again to cancel random playback.</li> </ul>
	<b>Folder back</b>	Use the <b>Folder back</b> button to move back to the previous folder.
	<b>Folder forward</b>	Use the <b>Folder forward</b> button to move forward to the next folder.
	<b>Skip back</b>	Use a short press on the <b>Skip back</b> button to skip back to the previous track. Press the <b>Skip back</b> button (for at least 2 seconds) for fast backward playing.
	<b>Skip forward</b>	Use a short press on the <b>Skip forward</b> button to skip forward to the next track. Press the <b>Skip forward</b> button (for at least 2 seconds) for fast forward playing.
	<b>Mute sound</b>	Press the <b>Mute</b> button to mute the music player. Press the <b>Mute</b> button again to cancel the mute action.
	<b>Start or pause music playback</b>	<ul style="list-style-type: none"> <li>– Press the <b>Play/Pause</b> button to start music playback.</li> <li>– Press the <b>Play/Pause</b> button again to pause music playback.</li> <li>– When the <b>Play/Pause</b> button is pressed to start music playback again, music resumes from the location the track stopped at when the music was paused.</li> </ul>
	<b>Stop music playback</b>	Press the <b>Stop</b> button to stop music playback. The LCD shows the total number of songs and folders.

Table 8.2: MP3 Playback button functions

The following buttons are used when the music player is in FM/AM tuner mode. For the location of each button, see item 5 in Section *Internal music unit*, page 32.

Button	Function	Instructions
<b>FM/AM</b>	<b>Switch between FM and AM bands / select region mode</b>	<ul style="list-style-type: none"> <li>– To switch between FM/AM bands, press the <b>FM/AM</b> button. The LCD shows “AM” or “FM”.</li> <li>– To select a different region mode, press <b>FM/AM</b> for more than 3 seconds, the LCD shows "EUR" or "USA". Change the current setting by pressing <b>Skip forward</b>, and then press <b>Memory</b> to store this setting. This will change the tuning grid to scan for radio stations. Other regions may adhere to the USA or European standard.</li> </ul>
<b>Tuner</b>	<b>Fine tune / scan FM/AM radio frequencies</b>	<ul style="list-style-type: none"> <li>– To fine tune an FM/AM frequency, use the <b>Tuner up</b> and <b>down</b> buttons.</li> <li>– To scan FM/AM frequencies, press the <b>Tuner up</b> or <b>down</b> buttons for at least 2 seconds to start an automatic scan search. Scanning stops when the FM/AM tuner can lock on to a strong radio station frequency.</li> </ul>
<b>Memory</b>	<b>Memory setting</b>	Saves the FM/AM mode and frequency pre-selections M1-M10.
<b>M1-M5</b>	<b>Pre-selection</b>	<p>Five frequency pre-selection buttons.</p> <p>To set a frequency pre-selection:</p> <ol style="list-style-type: none"> <li>1) Search and hold the frequency.</li> <li>2) Press the <b>Memory</b> button.</li> <li>3) Press a pre-selection button (<b>Mx</b>) for more than 1 second.</li> </ol> <p>To recall a pre-selected radio station press <b>Mx</b> for pre-selections M1-M5.</p>
<b>+5</b>	<b>Pre-selection</b>	<p>Frequency 6-10 pre-selection button.</p> <p>To set a frequency pre-selection 6-10:</p> <ol style="list-style-type: none"> <li>1) Search and hold the frequency.</li> <li>2) Press the <b>Memory</b> button.</li> <li>3) Press the <b>+5</b> button.</li> <li>4) Press a pre-selection button (<b>Mx</b>) for more than 1 second.</li> </ol> <p>To recall a pre-selected radio station press <b>+5</b> and then <b>Mx</b> for pre-selections M6-M10.</p>

**Table 8.3: FM/AM Tuner button functions**

### 8.2.6 Remote control button functions

The following illustration shows the layout of the remote control function buttons.

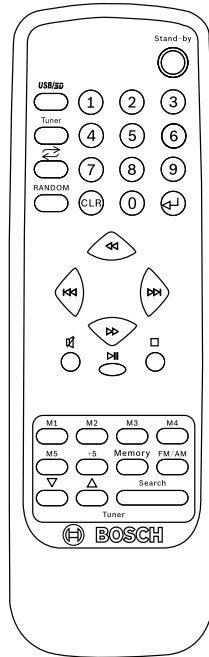

Figure 8.5: Remote control functions

All remote control button functions are the same as described for the music player, except for the following buttons that are only available on the remote control. See *Music player*, page 34.

Button	Function	Instructions
<b>0 - 9 + Enter</b>	<b>Select a specific song number or radio frequency</b>	In USB/SD playback mode: Use the numeric buttons to enter the number of the song to be played. The first two digits select the folder; the next three digits select the song. Then press <b>Enter</b> to start playback. In Tuner mode: Use the numeric buttons to enter the frequency of the radio station, then press <b>Enter</b> to tune to that frequency. If the frequency is invalid, the tuner returns to its previous state.
<b>CLR</b>	<b>Clear selection</b>	Press <b>CLR</b> to cancel the process of selecting a specific song number or radio frequency and return to the previous state.
<b>Search</b>	<b>Search and store radio stations</b>	In tuner mode: press <b>Search</b> for more than 5 seconds, then the tuner starts searching for radio stations and stores the first ten stations in M1-M10. Pressing any key interrupts the search process.

Table 8.4: Remote control button functions

### 8.3 Call Station operation

The following figure lists all items of the Call Station. This section only describes the operation of the Call Station. For information on connecting and configuring the Call Station, refer to:

- *Call Station connections, page 18*
- *Call Station hardware configuration, page 24*
- *Call Station software configuration, page 25*

The PLN-6CS Call Station is used for making announcements to selected zones of the All-in-One system.

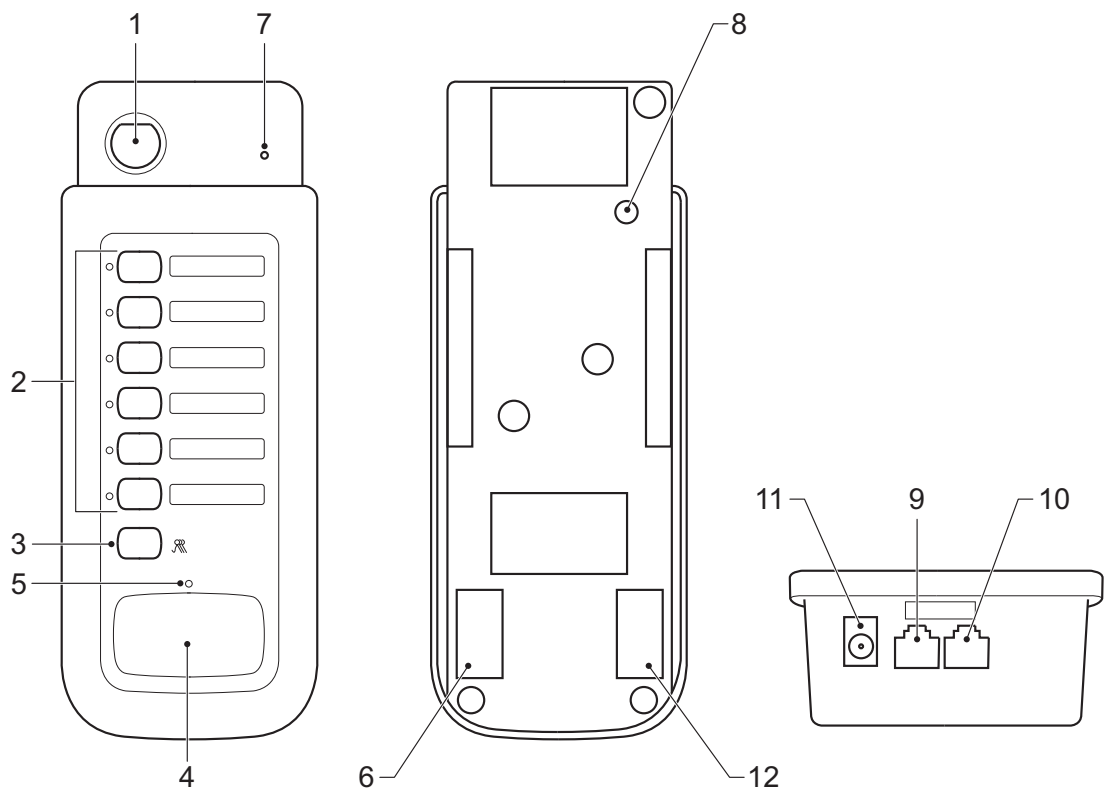

Figure 8.6: PLN-6CS Call Station functions

Number	Item	Description
1	<b>Goose neck condenser microphone</b>	A high quality unidirectional microphone.
2	<b>Zone buttons / Zone LEDs (1-6)</b>	<ul style="list-style-type: none"> <li>– To select a zone, press a zone button and the corresponding zone LED will go on.</li> <li>– To deselect a zone, press the zone button again and the zone LED will go out.</li> </ul>

Number	Item	Description
3	<b>All call button</b>	<ul style="list-style-type: none"> <li>- To select all zones, press the <b>All call</b> button, all zone LEDs will go on.</li> <li>- To deselect all selected zones, press the <b>All call</b> button again, the zone LEDs will go out.</li> </ul>
4	<b>Push To Talk (PTT) button</b>	<ul style="list-style-type: none"> <li>- When the PTT button is pressed and no call with a higher priority is busy from another call station or from the Telephone/Emergency input, then a call will be made to the selected zones. The Talk LED will light up green during the call. If an attention chime has been configured on this Call Station, the call will start with this chime and the Talk LED will flash during the chime as an indication to wait before talking. The zone indicators of the addressed zones on the All-in-One Unit will flash during the call. The call stops when the PTT button is released.</li> <li>- When the PTT button is pressed but the system is occupied by another call with a higher priority, then the Call Station will wait and the Talk LED lights up amber. When the higher priority call finishes, the Call Station will continue with the call and the Talk LED turns green. When the PTT button is released before the higher priority call finishes, the call is cancelled.</li> <li>- When the PTT button is pressed but no zones were selected before, then the Talk LED will light up amber. When the PTT button is kept pressed and no higher priority call is busy, after 3 seconds the previous zone selection will be used automatically and the Talk LED will turn green.</li> </ul>
5	<b>Talk LED</b>	<p>The Talk LED shows the status of the Call Station:</p> <ul style="list-style-type: none"> <li>- Off - no activity of this Call Station.</li> <li>- Amber - system occupied or no zones selected.</li> <li>- Green - call active, the user can speak.</li> <li>- Green flashing - call active, busy with attention chime.</li> </ul>
7	<b>Power LED</b>	<ul style="list-style-type: none"> <li>- Green LED on indicates power on.</li> <li>- Green LED off indicates power off.</li> </ul>

## 8.4 Wall Panel operation

This section only describes the operation of the Wall Panel. For information on connecting and configuring the Wall Panel, refer to:

- *Wall Panel connections, page 20*
- *Wall Panel configuration, page 28*

The PLN-4S6Z Wall Panel is used to remotely control the All-in-One Unit. The Wall Panel is connected to the All-in-One Unit with a Cat-5 cable and can take over operational control of the All-in-One Unit. Pressing the Enable button toggles between control on the front panel of the All-in-One Unit or control via the Wall Panel. The Wall Panel is capable of selecting a music source, selecting the zones that receive the music and it can control the master volume.

It also provides a microphone and line input with level control as a remote input for the All-in-One System.

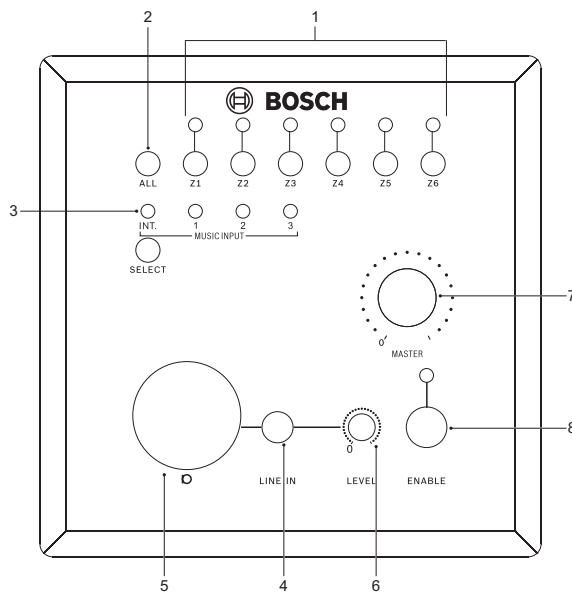

Number	Item	Description
1	<b>Zone 1-6 buttons / Zone 1-6 LEDs</b>	<ul style="list-style-type: none"> <li>- To select a zone, press a zone button and the corresponding zone LED will go on.</li> <li>- To deselect a zone, press the zone button again and the zone LED will go out.</li> </ul>
2	<b>All call button</b>	<ul style="list-style-type: none"> <li>- To select all zones press the <b>All</b> button, all zone LED lights will go on.</li> <li>- To deselect all selected zones, press the <b>All</b> button again, the zone LEDs will go out.</li> </ul>
3	<b>Music source selector</b>	Press the <b>SELECT</b> button repeatedly to select between the internal music player of the All-in-One Unit (USB/SD/Tuner) and Music inputs 1-3. The corresponding LED lights up to show the selection.



Number	Item	Description
7	<b>Remote Master volume</b>	Use the Remote <b>Master</b> volume control to change the master volume level of the All-in-One Unit. The remote master volume control is only functioning when it is enabled on the Wall Panel with the <b>Enable</b> button ( <b>7</b> ) or when it is enabled by setting the Music selector of the All-in-One Unit ( <b>7</b> ) to <b>Remote</b> .
8	<b>Enable button</b>	<ul style="list-style-type: none"><li>- To activate the wall panel, press the <b>Enable</b> button, the corresponding LED will go on.</li><li>- To deactivate the panel, press the <b>Enable</b> button again.</li><li>- The green Enable LED will flash fast (5 Hz) when a higher priority signal is active on the All-in-One Unit. This can be a signal on the Telephone/Emergency input or from a call station. The Enable LED will flash slowly (1 Hz) when it is deactivated.</li></ul>

## 9 Troubleshooting

Problem	Possible cause	Potential solution
USB/SD Storage device not detected	Device does not comply with USB mass storage specifications.	Use a device that complies with the USB mass storage class. <b>Note:</b> some audio players, included in the class of image devices are not supported. Also some flash card readers cannot be detected.
	USB hub in use.	Some USB hubs will not operate properly. If this is the case, try using a different USB hub or connecting the storage device directly to the USB port. <b>Note:</b> if multiple USB storage devices are connected through a USB hub, only one of the storage devices will be recognized.
	Format not supported.	Use only FAT16 or FAT32 format.
	The connection to the unit is terminated due to USB port power supply current overload.	Wait several minutes. The rating (allowable current) for this unit is 500 mA maximum. Only use USB storage devices that meet these standards. If the USB port is shorted for a long time, it will be damaged.
	Partitioning of the SD card or USB device is wrong.	Reformat the USB or SD card with a PC that is known to give good results.
MP3 or AAC tracks cannot be played	Format not supported.	See section <i>Internal music unit</i> , page 32 on supported formats. <b>Note:</b> MP3 format is supported up to 320 kbps.
	Files are copy protected.	Copy protected files cannot be played on this unit.
No sound output	Audio cables are loose and/or not connected properly.	Check to ensure the audio cables are securely connected to the unit.
	Audio mixer is not working correctly.	Check the music source selector and volume settings on the audio mixer.

Problem	Possible cause	Potential solution
	Phantom power is disabled for an electret or condenser microphone.	Enable the phantom power supply or use a dynamic microphone.
	Connection jumper is missing between Insert out and Insert in to connect the power amplifier input to the pre-amplifier output.	Replace jumper or use a short cable with two RCA plugs.
	Music player control is in pause or mute mode.	Press the play / mute button to begin playback.
Sound is distorted or noisy	Audio cable is loose and/or not connected properly.	Connect the audio cable to the line input jack of the DJ audio mixer.
	Jacks and/or jack plugs are dirty.	Wipe away dust or dirt and reinsert jack plugs.
Unit does not work	The power cord is disconnected or unit has been switched off.	Insert the power cord and switch on the unit.

## 9.1 Customer service

If a fault cannot be resolved, please contact your supplier or system integrator, or go directly to your Bosch representative.

## 10 Maintenance

The units require minimum maintenance, however to keep the units in good condition, the following tasks should be carried out.

- Clean the units:
  - Periodically clean the units with a damp, lint-free cloth.
- Clean the air inlets:
  - The units can collect dust from the operation of the internal fans. The air inlets of the units should therefore be cleaned on a yearly basis.
- Periodically check unit connections and grounding:
  - To ensure that all cable connections to the units are secure.
  - The ground (Protective Earth) connection of the system components.



### **Warning!**

Dangerous mains voltages are present inside the units. Disconnect the main power supply before doing any maintenance tasks.

---

# 11 Technical Data

The following data relates to the PLN-6AIO240 Plena All-in-One Unit and its associated products, PLN-6CS Call Station and PLN-4S6Z Wall Panel.

## 11.1 All-in-One unit

### Electrical

<b>Mains power supply</b>	
Voltage	115/230 Vac +/- 15%, 50/60 Hz
Fuse rating	6.3 A (230 Vac) 10 A (115 Vac)
Power consumption	720 W max

<b>Performance</b>	
Frequency response	Microphone inputs: 100 Hz – 15 kHz +1/-3dB Line inputs: 50 Hz – 20 kHz +1/-3dB (+1/-3 dB @ -10 dB ref. rated output)
Distortion	<1% @ rated output power, 1 kHz
Bass control	+/- 8 dB @ 100 Hz
Treble control	+/- 8 dB @ 10 kHz

<b>Remote devices</b>	2 x
Call station input	RJ45 for PLN-6CS
Wall panel input	RJ45 for PLN-4S6Z

<b>Microphone/Line input</b>	6 x
Input 1 (Push-to-talk contact for priority/ducking)	RJ45 for PLE-1CS or PLE-1SCS 3-pin XLR, balanced, phantom
Input 2-6 (with signal detector for priority/ducking)	3-pin XLR, balanced, phantom
Sensitivity	1.5 mV (mic); 200 mV (line)
Impedance	>600 ohm (mic); >10 kohm (line)
S/N (flat at max volume)	>65 dBA (mic); >70 dBA (line)
CMRR (mic)	>40 dB (50 Hz to 20 kHz)
Headroom	>25 dB
Phantom power supply	18 V – No load
Level detector (VOX) on Inputs 1-6	Attack time 150 ms; release time 3 s

<b>Battery power supply</b>	
Voltage	24 Vdc (22 Vdc – 28 Vdc)
Current	12 A

<b>Music inputs</b>	3x
Connector	Cinch, stereo converted to mono
Sensitivity	500 mV (inputs1/2) and 300 mV (input 3)
Impedance	10 kohm
S/N (flat at max volume)	>65 dBA
S/N (flat at min volume/muted)	>75 dBA
Headroom	>20 dB

<b>Emergency / telephone</b>	1 x
Connector	7-pin, Euro style pluggable screw terminal
Sensitivity line input	100 mV
Sensitivity 100V input	100 V
Impedance line input	600 ohm
S/N (flat at max volume)	>70 dBA
Level detector (VOX)	Threshold 50 mV; attack time 150 ms; release time 3 s

<b>Insert</b>	1 x
Connector	Cinch
Nominal level	1 V
Impedance	>10 kohm

<b>FM tuner</b>	
Distortion	<1 %
Total harmonic distortion (1 kHz)	< 0.8 %
FM range	87.5 - 108 MHz
Frequency response	60 Hz - 12 kHz
Intermediate rejection	≥ 70 dB
Image rejection	≥ 50 dB

S/N ratio	≥ 50 dB
Intermediate frequency	10.7 MHz
Input sensitivity	8 μV
Automatic tuning sensitivity	≤ 50 μV
Antenna input	75 ohms (coaxial)

<b>AM tuner</b>	
AM range	530 - 1602 kHz
Input sensitivity	30 μV

<b>Digital audio player</b>	1 x
Frequency response	20 Hz to 20 kHz
S/N ratio	>70 dBA
Total harmonic distortion (1 kHz)	<1 %
Supported formats	MP3, 32 - 320 kbps

<b>Master/music output</b>	1 x
Connector	3-pin XLR, balanced
Nominal level	1 V
Impedance	<600 ohm

<b>Loudspeaker outputs 100 V</b>	
Connector	Screw, floating
Total power	240 W
Direct outputs	100/70 V, 8 ohm
Zone outputs 1-6	100/70/50/35/25/17 V

### Mechanical

Dimensions (H x W x D)	133 x 430 x 365 mm with feet (19" wide, 3 U high)
Weight	Approx. 18 kg
Mounting	Standalone, 19" rack
Color	Charcoal

**Environmental**

Operating temperature	-10 °C to +45 °C (14 °F to +113 °F)
Storage temperature	-40 °C to +70 °C (-40 °F to +158 °F)
Relative humidity	<95% (non-condensing)

**Generic performance specifications**

Acoustic noise	< 45 dB SPL, measured at 1 meter above the unit
MTBF	1200000 hours at 25°C



## 11.2 Call Station

### Electrical

<b>Power Supply</b>	
Voltage	24 Vdc (24 Vdc supplied by PLN-6AIO240)
Current consumption	<50 mA
<b>Performance</b>	
Nominal acoustic sensitivity	85 dB SPL @ 1 kHz (gain preset 0 dB)
Nominal output level	1 V
Input sound level (max.)	110 dB SPL
<b>Gain preset</b>	
Limiter threshold	1 V
Compression ratio limiter	1:20
Distortion	<2% (maximum input)
Input noise level (equiv.)	25 dBA SPL
Frequency response	100 Hz to 14 kHz +/-6 dB
Speech filter	-3dB @ 315 Hz, high-pass, 6 dB/oct
Output impedance	200 ohm
<b>Selections</b>	
Chimes	1-, 2- or 4-tone chime selected on Call Station

### Mechanical

Base dimensions (H x W x D)	55 x 108 x 240 mm (1.57 x 3.97 x 9.25 in)
Weight	Approx. 0.5 kg (1.1 lb)
Mounting	Tabletop
Color	Charcoal with silver
Stem length with microphone	390 mm (15.35 in)
Connection	2 x RJ45, Cat-5, max. length 600 m

### Environmental

Operating temperature	-10°C to +45°C (14°F to +113°F)
Storage temperature	-40°C to +70°C (-40°F to +158°F)
Relative humidity	<95% (non-condensing)

## 11.3 Wall Panel

### Electrical

<b>Power supply</b>	
Voltage range	24 Vdc, supplied by the connected amplifier
Current consumption (typical)	<50 mA
Connector	1 x RJ45 socket (inside Wall Panel)

### Mechanical

Dimensions (H x W x D)	115 x 115 x 70 mm (4.5 x 4.5 x 2.8 in)
Weight	Approx. 0.6 kg (1.3 lb)

### Environmental

Operating temperature	-10°C to +45°C (14°F to +113°F)
Storage temperature	-40°C to +70°C (-40°F to +158°F)
Relative humidity	<95% (non-condensing)

## 11.4 Safety compliance

The following data relates to the PLN-6AIO240 Plena All-in-One Unit and its associated products, PLN-6CS Call Station and PLN-4S6Z Wall Panel.

Safety	IEC/EN 60065
EMC	EN 55103-1 EN 55103-2 EN 61000-3-2 EN 61000-3-3
Environment	EN 50581
US	UL 60065 FCC Part 15B
CA	CSA C22.2.60065
CN	CCC
AU/NZ	C-Tick



**Bosch Security Systems B.V.**

Torenallee 49

5617 BA Eindhoven

The Netherlands

**[www.boschsecurity.com](http://www.boschsecurity.com)**

© Bosch Security Systems B.V., 2014